

GD 800

USER MANUAL

Be sure to read this manual in detail and keep it properly



GUNG DAI TECHNOLOGY CO., LTD.
17F., NO. 2-106, WUQUAN RD., WEST DIST., TAICHUNG TAIWAN, 40355
<https://www.gungdai.com.tw/en>

Safety Instructions



Please read the following instructions carefully.

When operating electronic devices, please comply with the basic safety precautions and descriptions below:

1. Do not place power cords, plugs, or devices in water or other liquids to avoid electric shock.
2. Do not operate if the power cord or plug is damaged, or if the device is malfunctioning. Please return the device for further inspection, repair, or adjustment.
3. Do not use the device outdoors or in damp areas.
4. Do not let the power cord hang over the edge of a table or counter, or contact hot surfaces.
5. Do not use this device for other purposes besides home use.
6. When using this equipment, keep two to three inches of space around the device for a good ventilation.
7. Do not attempt to repair the product yourself. Repairs should be carried out by qualified technician.
8. Keep children away from operation. Hot water can cause severe scalds.
9. This appliance is not intended for use by persons including children with reduced physical, sensory, or mental capabilities, or lack of experience and knowledge, unless they have been given supervision or instruction concerning use of the appliance by a person responsible for their safety.
10. Children must be supervised to ensure that they don't play with the appliance.
11. If the power cord is damaged, it must be replaced by the manufacturer, its service agent, or similarly qualified persons in order to avoid a hazard.
12. Please use the new tubes that supplied with the appliance, do not use the old tubes.
13. Avoid splashing liquids on the connector.
14. There may be residual heat retained on the faucet after use, so please do not touch the faucet body to avoid scalds.

Installation

Parts and Materials Needed

Materials

1. 1/2" or 3/4" water T-adapter
2. Stop valve
3. 1/4" valve
4. 1/4" RO tube, length adjust as needed

Tools

1. Phillips screwdriver
2. Power drill
3. Pilot drill as needed
4. Safety goggles
5. Bucket
6. Pliers
7. Gloves
8. 35mm hole opener
9. Pipe cutter
10. Thread seal tape
11. Adjustable wrench

Site Requirements

1. A filtered or clean water source is required.
2. A drainage system is required.
3. A dedicated (110V 15A/220V 15A) power supply is required. The use of extension cords is not recommended.

-  1. All tubes are NSF/FDA certified, non-toxic TPFE tubes.
- 2. This product cannot continuously produce hot water. The standard model produces 60 cups (300 ml) of hot water per hour.
- 3. The GD 800 hot tank has a pressure relief design; it is normal for hot water to come out slowly at first

 Required materials must be prepared by the installation personnel and in compliance with local regulations.

Parts and Specifications

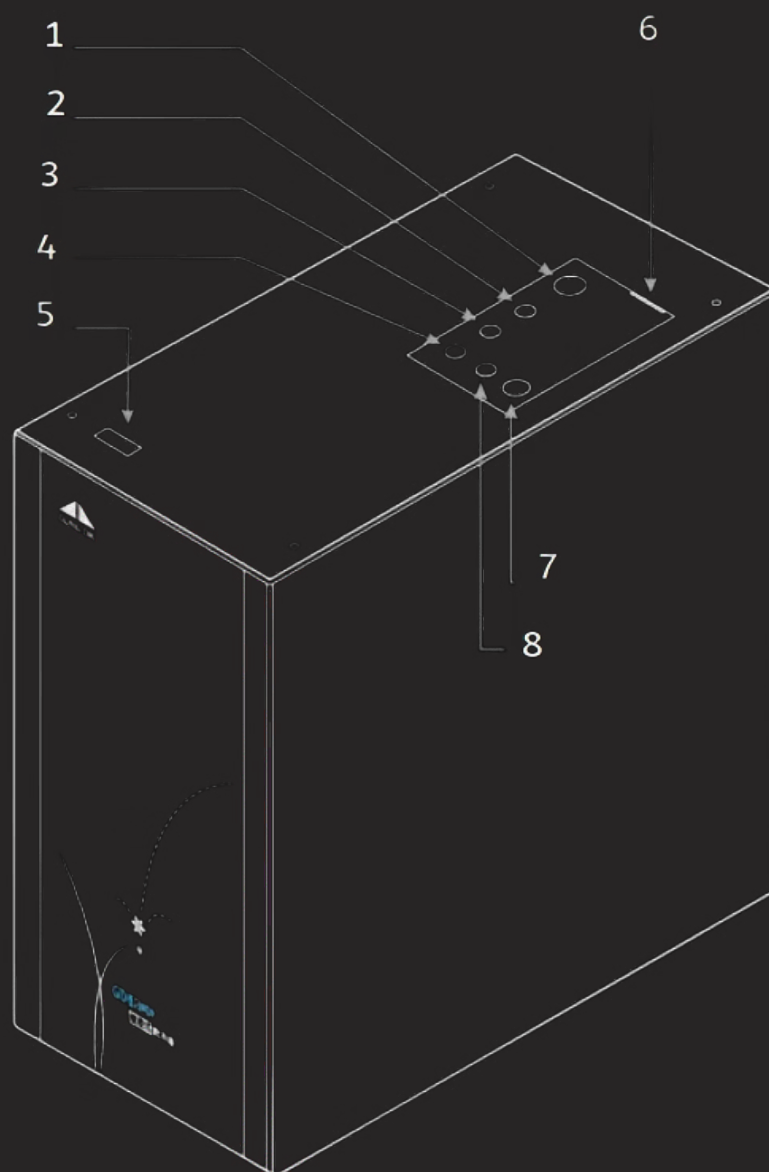

Parts

1. Hot water outlet
2. Ambient water outlet
3. Cold water outlet
4. Water source inlet
5. Cold water ON/OFF
6. Faucet signal port
7. Cooling water outlet
8. Cooling water inlet

Items	Specifications
Voltage	110V / 60Hz, 220V / 50Hz
Main Unit Dimensions	23(W)×43(D)×42.5(H) cm
Water Pressure	20-45 PSI
Power Cord	3x2.0mm
Capacity	2.4 L (Hot) / 2.0 L (Cold)
Power Consumption	850W (110V) / 1350 W (220V)
Heating Capacity	10L/h
Cooling Capacity	5L/h
Hot tank	ST-304 (Stainless Steel)
Heating Element	ST-316 Medical grade ring type heater
Country of Origin	Taiwan
Faucet Installation Hole	35mm Diameter

Faucet Dimensions

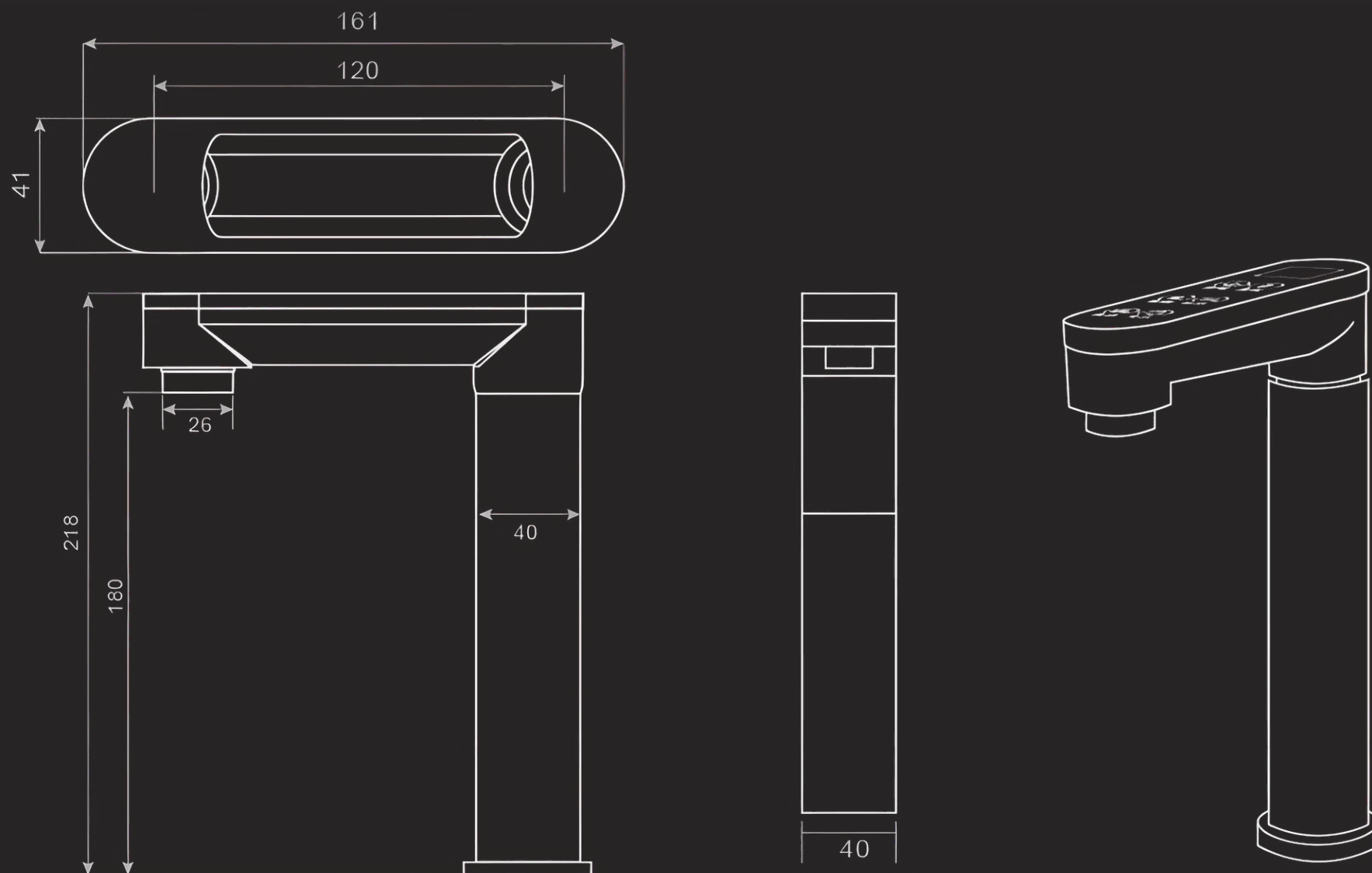

- ⚠ 1. Before connecting the GD800 to a power source, please ensure that the voltage, current, and power cord specifications match the instructions. Unauthorized changes to the power source or device structure may cause malfunctions or hazards. We are not responsible for any personal injury or property damage resulting from failure to follow these instructions.
- 2. Must use a dedicated outlet and be connected to a dedicated ground wire. Do not use an extension lead.
- 3. Please install a leakage breaker at the water filtration end to ensure safety.
- 4. Please install a relief valve if the water pressure exceeds 45 PSI.
- 5. Please ensure the hot-resistant tube is not twisted or knotted. The hot tank must be installed vertically, and the tube can be shortened if necessary.
- 6. Do not use adhesive for faucet installation.

- ⓘ 1. Faucet Installation Hole: Diameter 35 mm
- 2. Faucet Rotation: 180 degree

Initial Setup

Enter the Dealer-exclusive Password

1. Please follow the steps to fill the hot water tank full before turning on the power
2. Press UNLOCK button first.
3. Press HOT button, the hot water comes out if the hot tank is filled.



100

TEMPERATURE

Display temperature (reference value)



POWER/ENERGY SAVING

Press 6 seconds to start the water dispenser. Press again to start ENERGY SAVING, the hot water stops heating for 8 hours.



UNLOCK

Press UNLOCK to unlock hot water function.



HOT

Hot water switch. (The device is designed to continuously supply water for 120 seconds.)



TEMP

Select your preference of hot water temperature (72/88/98°C).



COLD

Cold water switch. (The device is designed to continuously supply water for 120 seconds.)



AMBIENT

Ambient water switch. (The device is designed to continuously supply water for 120 seconds.)

- ⚠ 1. Do not use strong acids or strong alkalies corrosive solvents for cleaning.
- 2. Please clean with neutral detergent and soft cloth
- 3. Please do not use tap water to directly rinse the digital faucet.

Instructions & Precautions

Instructions

1. Place cold water tank upright to avoid air blockage issues.
2. The external temperature sensor prevents ice formation on the inner wall of the tank, avoiding non-stop operating and potential barrel rupture.
3. The cold water system uses the environmentally friendly refrigerant R134a.
4. Good insulation materials, refrigeration about once every 2 hours.
5. The capacity of cold tank is about 2 liters. Supplying approx. about 4 liters/hour at 12°C.

Precautions

Please set your **GD800** according to the instructions below if you are away from home for more than 5 days:

1. Turn off the water source.
2. Turn off the cold tank switch (red switch on top of the unit).
3. Press the "**POWER**" on the upper left of the faucet for 5~6 seconds until the display shows " _".
4. Unplug the main unit.

Following the instructions below to resume water supply:

1. Open the water source.
2. Plug in the power cord of main unit.
3. Press the hot water button to let it flow for 2 minutes twice (press the hot water button until it stops automatically twice; water can still flow even when the faucet is not turned on).
4. Press the **POWER** button on the upper left of the faucet for 5~6 seconds to start, after that the main unit will automatically fill with water and heat up, and ready for use once heating is complete.
5. Press **COLD** button to let it flow for 2 minutes till it automatically stops, make this operation twice.
6. Turn on the ice tank power switch. It takes about half an hour for the water to cool down and become drinkable.

Troubleshooting

Q Why is there a difference between the actual water temperature and the temperature displayed on the panel?

A The actual temperature of the hot water is affected by the ambient temperature of the tube connecting the hot tank to the faucet. The longer the tube, the bigger the effect.

Q Why does the faucet drip during the heating process?

A To prevent the issues like excessive pressure and sewage backflow, all GD series hot tanks are equipped with pressure relief system. As a result, during the heating process, the steam converts to water and is discharged from the faucet which is a normal circumstance. This can also happen if the water input pressure is below 20 PSI; adjusting the pressure appropriately can fix the problem in this case.

Q What is the reason for the main unit leaking?

A It could be that the hot water tube was bent during installation, causing back pressure and resulting in leaking. Please turn off the the water source switch and unplug the power cord from the socket.

Then, please contact your maintenance personnel for an on-site inspection.

Q Why are there white sediments appearing in the water after using water dispensers for a while?

A It's normal for water to contain trace minerals naturally. Magnesium and calcium can form white sediment when heated. These sediments are harmless when consumed in small amounts. However, we strongly recommend performing a major maintenance every four years to ensure the longevity and sanitation of your device.

Q Does the heater of the GD water dispensers release contaminant during the heating process?

A All heaters in the GD series water dispensers are UL certified by the United States and made with medical-grade ST-316 stainless steel. They are completely harmless and do not release contaminants like other copper heaters. Moreover, GD's heater are two times bigger than the traditional type, which are more efficient and energy-saving.

Q Does the GD series water dispenser require regular maintenance?

A Yes, we recommend performing major maintenance for your GD series water dispenser at least every four years, and more frequently if the source water in your area is lower quality. This keeps the longevity and hygienic for your water dispenser.

Please contact your maintenance personnel for further detail.

Troubleshooting

Q Why the capacity of GD series hot tanks is smaller than other brands?

A The hot tanks in GD series water dispensers are intentionally designed smaller because consumer habit analysis revealed that a 2.4-liter hot tank is sufficient for general once consumption. This design primarily enhances energy efficiency and positions GD ahead of competitors.

Q Where are GUNGDAI products made?

A The GUNGDAI series are 100% made in Taiwan. GUNGDAI, hereinafter referred as GD, is a Taiwanese brand with a global presence. Renowned for its top-notch quality, excellent artwork design and impeccable craftsmanship. GD stands as a premium home appliance brand that perfectly integrates into any luxury interior decorations, making it the go-to choice for those who settle for nothing but the best.

Q What is the power consumption of the hot drink machine in standby mode?

A The power consumption is about 486 W a day.

Q Why does the drinking water have an odor?

A The taste, smell and odors are mainly related to water filter cartridges.

This could be due to a change in your water usage habits or not replacing the filter regularly. If you are used to drinking RO purified water and suddenly switch to mineral water, the change in mineral content can alter the taste and affect the drinking experience.

If you have any other issues or need service, please contact your local service provider.

Restricted Substances List (RSL)

	Power Cord [1]	Metal Parts [2]	PCB Assemblies [3]	Plastic Parts [4]
Lead (Pb)	○	○	○	○
Mercury (Hg)	○	○	○	○
Cadmium (Cd)	○	○	○	○
Hexavalent Chromium (Cr ⁶⁺)	○	○	○	○
Polybrominated Biphenyls (PBB)	○	○	○	○
Polybrominated Diphenyl Ethers (PBDE)	○	○	○	○

[1] Including internal and external wiring

[2] Including heating plates, screws, outer casing, heating elements

[3] Including printed circuit boards and components, such as resistors, capacitors, inductors, integrated circuits, etc

[4] Including water tanks and pipes

- ⚠ 1. "Exceeding 0.1 wt%" and "Exceeding 0.01 wt%" indicate that the content of restricted substances exceeds the percentage concentration limit.
- 2. "○" indicates that the content of the restricted substance does not exceed the percentage concentration limit.
- 3. "—" indicates that the restricted substance is exempted.

All GUNGDAI's products have two years warranty from the date of purchase and installation (excluding water filtration equipment). If repairs are needed, please contact the selling distributor.

There are situations where repairs may incur charges during the warranty period, as outlined below:

- If the usage does not comply with the instructions.
- If used with sources other than general tap water, such as unfiltered water.
- Damage caused by dropping or other human factors after purchase.
- If the warranty certificate does not record the purchase date, customer name, or store name, or if it has been altered.
- Malfunctions caused by natural disasters such as earthquakes, floods, or fires.
- If the filter materials are not replaced according to the company's specified schedule.
- If there is no warranty certificate.



GUNG DAI TECHNOLOGY CO., LTD.
 17F., NO. 2-106, WUQUAN RD., WEST DIST., TAICHUNG TAIWAN, 40355
<https://www.gungdai.com.tw/en>